



Article

Implementation and Monitoring Water Drinking Necessary on Smart Dispenser with IoT-Based

Rahmat Novrianda Dasmien¹, M. Yahya^{2*}

^{1,2} Bina Darma University, Computer Engineering, South Sumatera, Indonesia

SUBMISSION TRACK

Received: 01, 29, 2024

Final Revision: 07, 24, 2024

Available Online: 08, 08, 2024

KEYWORD

Conventional Dispenser, Color Sensor, Fingerprint Sensor, IOT

CORRESPONDENCE

E-mail:

yahyaya068@gmail.com

A B S T R A C T

Conventional dispensers have limitations in providing drinking water tailored to user preferences and do not focus on efficient resource use. This research aims to address these issues by designing and implementing a smart, efficient automatic dispenser. An experimental method was used to develop an Arduino-based prototype consisting of several components: flow sensor, color sensor, fingerprint sensor, proximity sensor, DC pump, motor driver, NodeMCU, and LCD. The flow sensor measures water volume, the color sensor detects glass color, the fingerprint sensor identifies the user, and the proximity sensor detects the presence of the glass. The DC pump flows water from the tank to the glass, relays and solenoids control the water flow, NodeMCU processes sensor data and connects to IoT, and the LCD displays the required information. A battery backup ensures functionality during power outages. The research results show that the automatic dispenser performs well and meets the research objectives. It provides drinking water according to user preferences: warm water for red glasses, cold water for blue glasses, and room temperature water for green glasses. Additionally, it identifies users through fingerprints and sends notifications via Telegram chatbots. This smart dispenser offers a more efficient and user-friendly solution compared to conventional dispensers.

I. INTRODUCTION

Dispensers are devices that have become an integral part of our daily routine, used to collect drinking water easily and quickly [1], [2]. However, conventional dispensers often only provide water at one specific temperature, which may not suit user preferences. In addition, these dispensers often do not consider efficiency in the use of water, energy and other resources. As a result, there is significant waste in water and energy use, which not only harms users, but also has a negative impact on the environment. The limitations of conventional dispensers are the main motivation for the development of smarter and more efficient dispensers.

In order to overcome this problem, this research aims to design and implement an automatic dispenser that utilizes flow, proximity and color sensor technology where when someone places a glass, the dispenser will automatically fill water according to the predetermined amount of water that will be filled by the dispenser. This depends on the color of the glass, if the glass tends to be red then the dispenser will fill warm water if the glass tends to be blue then the dispenser will fill cold water, if not both then the dispenser will fill water at normal temperature, all of these systems are connected to IoT to be able to monitoring system and also this system has backup power that comes from the battery. If the power goes out, the system can still be used.

II. LITERATURES REVIEW

Flow Meter Sensor

A sensor is a component used to detect a physical quantity into an electrical quantity so that it can be analyzed using a certain electrical circuit. A flow sensor is a sensor device used to measure fluid flow. Flow sensors are parts used in flow meters [3]. These sensors are generally used in various applications, including automatic dispensers, to measure the amount of flowing water and regulate the water filling process. Flow sensors work by measuring changes in pressure or fluid flow speed and converting them into data that can be used by the control system.

Color Sensor

TCS 3200 is an IC (Integrated Circuit) converting light color to frequency. There are two main components that make up this IC, namely the photodiode and the current to frequency converter. The photodiodes on the TCS3200 IC are arranged in an 8 x 8 array with a configuration: 16 photodiodes to filter red, 16 photodiodes to filter green, 16 photodiodes to filter blue, and 16 photodiodes without a filter [4]. Color sensors can be interpreted as a special spectrum found in ideal or perfect white light. There are two main categories of color, namely basic colors and derived colors. Basic colors refer to basic colors, while derived colors are the result of mixing two basic colors in a color space. For example, it can be seen below. In the context of graphics equipment, there are three basic colors of light: (R = Red) red, (G = Green) green, and (B = Blue) blue, which is better known as RGB. When combined in a certain composition, these three colors can produce a variety of colors.

Finger Print Sensor

A fingerprint sensor is a device that utilizes the unique principles of each human fingerprint for identification and authentication purposes [5]. The way it works focuses on creating a digital image of a person's fingerprint pattern. There are several types of technology used in fingerprint sensors, one of which is capacitive technology. In capacitive sensors, the sensor surface is coated with a small number of capacitors whose capacitance will change when a fingerprint touches the surface.

The fingerprint sensor working process has several stages, namely data acquisition, processing and verification [6]. In the data acquisition stage, the sensor collects fingerprint information by scanning the surface of the finger placed on the sensor. The resulting data is converted into a digital representation in the form of a fingerprint template. After that, at the processing stage, this fingerprint template is compared with the existing template in the database. If there is sufficient similarity, authentication is granted. This process is very effective because the fingerprint pattern is unique to each individual, thereby enabling a high level of security in a variety of applications, such

as device locking, access to buildings, or even individual identification in security and forensic applications.

NodeMCU

NodeMCU is an electronic board based on the ESP8266 chip with the ability to carry out microcontroller functions and also an internet connection (WiFi). There are several I/O pins so that it can be developed into a monitoring and controlling application for IoT projects. The NodeMCU ESP8266 can be programmed with the Arduino compiler, using the Arduino IDE. The physical form of the NodeMCU ESP 8266 has a USB port (mini USB) so it will make programming easier [7].

By default, the term NodeMCU actually refers to the firmware used in the NodeMCU development kit hardware, which can be analogous to the ESP8266 Arduino board [8]. The history of the birth of NodeMCU is close to the release of the ESP8266 on December 30 2013, Espressif Systems as the maker of the ESP8266 started production of the ESP8266 which is a Wi-Fi SoC integrated with the Tensilica Xtensa LX106 processor [9]. Meanwhile, NodeMCU started on October 13, 2014 when Hong committed the first nodemcu-firmware file to Github.

DC Pump

A DC pump is a device used to flow water from a reservoir to the user's glass or container [10]. This pump works on the principle of moving water through a pipe system using energy from a DC electricity source. DC Water Pump is a type of pump that relies on a DC motor and uses direct voltage as a power source [11]. Its working principle involves applying a voltage difference to the two terminals of the motor; so, the motor will rotate in one direction. Conversely, if the voltage polarity is reversed, the direction of rotation of the motor will change. Therefore, the direction of rotation of the motor on a DC water pump is determined by the polarity of the voltage applied to the two motor terminals [12].

Driver Motor

The driver is an arrangement of transistors that functions to drive a DC motor [13], [14]. Even though the motor can rotate with DC power, a driver is needed to control the movement of the motor. This driver circuit plays a role in controlling the motor's work.

A DC (direct current) motor is a basic electromechanical device that converts electrical energy into mechanical energy. DC motors use direct voltage as a power source. By applying a voltage difference to the two motor terminals, the motor will rotate in one direction. If the voltage polarity is reversed, the direction of rotation of the motor will also be reversed. The direction of rotation of the motor is determined by the polarity of the voltage on the two terminals, while the magnitude of the voltage difference determines the motor speed. In this context, the driver plays an important role in regulating voltage differences and controlling the direction and speed of rotation of the DC motor.

III. FRAMEWORK

IoT-Based Water Use Control and Monitoring System Using the ESP8266 Module [15]. This research aims to overcome challenges in controlling water usage costs for households and businesses. The author took inspiration by taking the concept of calculating flow and use of clean water.

IV. METHODS

The following is a system block diagram of the circuit used.

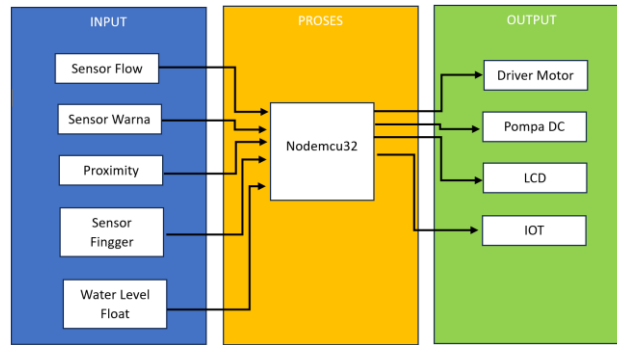

Figure 1. Block Diagram System

Making an automatic dispenser can be described in three stages, namely input, process and output. These three stages are interrelated and complement each other.

1. Flow sensor which functions to calculate the volume of water that has been released.
2. Color sensor which functions as a glass color detector to become a reference for the water that will be dispensed by the dispenser.
3. The proximity sensor functions as an indicator for the system to find out if there is a glass.
4. Finger sensor to identify who drinks the water.
5. Water level float to find out whether the system still has enough water. It works the same as a float.

This system has a data processor from the input, namely nodemcu which will control the DC pump based on the input data and display the data to the LCD and IoT.

This system has 4 outputs namely:

1. Motor driver which functions to control the DC pump.
2. DC pump which functions to suck water from the reservoir that has been prepared.
3. The LCD functions to display the required data.
- IoT which will send information data from the system.

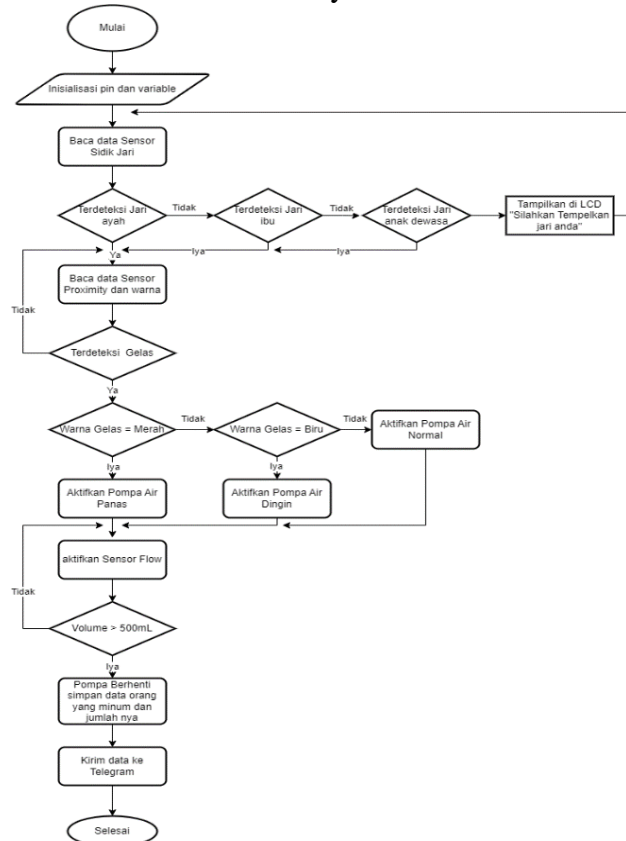

Figure 2. Flow chart sistem

This automatic dispenser uses a flow meter sensor, wanra sensor, finger print sensor, water level float and proximity sensor. The main source is using PLN electricity and backup from the battery. How the tool works is as follows.

1. When the device is turned on, the dispenser will check the finger print sensor. If a fingerprint is detected, the system will check whether the fingerprint has been previously saved. If yes, the proximity sensor will detect the object and then the system will identify the color of the object.
2. If the color tends to be red then the pump on the warm water motor will be active or if it tends to be blue then the cold water pump will be active otherwise the pump will activate the water at normal temperature.
3. When the pump is active the hose on the pump has been modified by adding a flow sensor so that when the flow meter has finished calculating the flow of water provided the system will stop and send data to IoT.

The following is a schematic of the smart dispenser series that has been created.

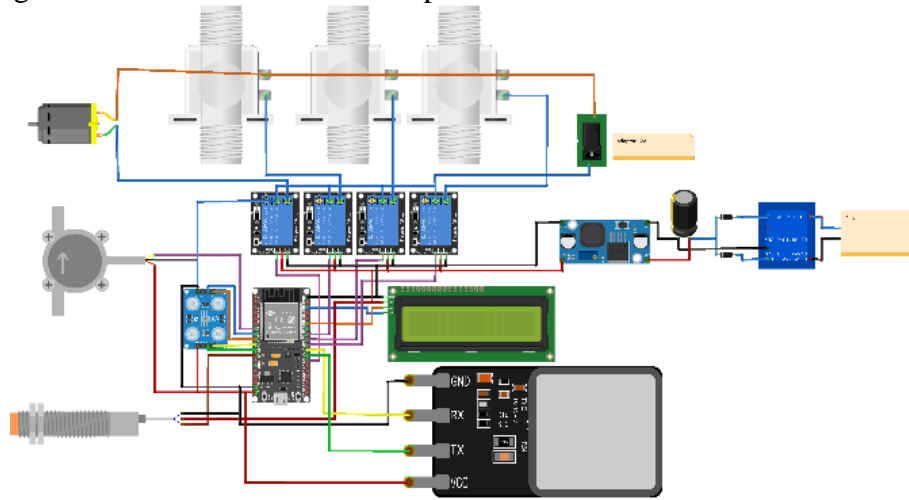

Figure 3. Circuit Schematic

V. RESULT (hasil perhitungan)

To get the desired results the author conducted experiments first on each component. Following are the results of the experiments that the author has made.

Color Sensor Testing

In this test, prepare 3 glasses to be tested, namely red, green and blue glasses. Place the glasses in front of the sensor. The data obtained is the RGB value of the color detected.



Figure 4. Color Sensor Testing

Below are the sensor reading results for each glass color.

Table 1. Red Glass Color Sensor Test Results

No	Sensor Results		
	R	G	B

No	Sensor Results		
	R	G	B
1	140	70	50
2	155	100	60
3	160	100	60
4	130	80	40
5	135	110	78

Table 2. Green Glass Color Sensor Test Results

No	Sensor Results		
	R	G	B
1	60	60	80
2	65	70	70
3	70	65	75
4	65	75	75
5	70	60	80

Table 3. Blue Glass Color Sensor Test Results

No	Sensor Results		
	R	G	B
1	80	70	110
2	70	50	120
3	80	80	115
4	90	75	120
5	70	70	115

The results obtained from testing each glass 5 times will give you the range of each glass color

- Red = ((R > 100 && B < 175) && (B < 100 && G < 120))
- Green = ((G > 50 && G < 85) && (B < 90 && R < 80))
- Blue = ((B > 100 && B < 135) && (R < 100 && G < 100))

After getting the sensor range, the author carried out experiments on the glass 10 times, and here are the results.

Table 4. Glass Testing

No	Glass	Sensor	information
1	RED	RED	Succeed
2	RED	Green	Fail
3	RED	RED	Succeed
4	RED	RED	Succeed
5	Blue	Blue	Succeed
6	Blue	Green	Fail
7	Blue	Blue	Succeed
8	Green	Green	Succeed
9	Green	Green	Succeed
10	Green	Green	Succeed

After testing 10 times, there were 8 successes and 2 failures when detecting the blue color, it was detected as green and when the red glass was detected as green.

Flowmeter Sensor Testing

In this test, prepare a measuring cup to be a barometer for the success of measuring the volume of water on the flow meter sensor, then activate the system to fill the glass with water and pour the water in the glass into the measuring cup and compare the measurement results with the measuring cup and sensor. Below are the test results.



Figure 5. Sensor Flow meter

In the picture above are the flowmeter and solenoid valve which function to open or close the water output connected to the flow meter because it matches the color of the glass which is detected if red = hot, blue = cold, green = normal.

Table 5. Flow Meter Test Results

No	Sensor (ml)	Measuring cup (ml)	Difference
1	100	110	+10
2	120	122	+2
3	150	155	+5
4	250	254	+4
5	350	340	-10
6	450	440	-10
7	600	620	+20
8	700	710	+10
9	800	780	-20
10	900	910	+10

After carrying out 10 experiments, the data obtained is that the sensor can read the volume of water supplied but gets a difference of +20 - (-10), then from this data the system is good for use.

Fingerprint Sensor Testing

In this test, prepare 3 fingers to be registered on the finger print as registered fingers, then prepare the sensor to carry out the test. The author carried out 10 experiments with a combination of the 3 identified fingers. After registering according to the ID data above, the following are the results of the experiment. that the author created.

Table 6. Fingerprint Sensor Testing Results

No	Jari	Sensor	Keterangan
1	Father (1)	1	Succeed
2	Father (1)	1	Succeed
3	Father (1)	0	Not detected
4	Mother (2)	2	Succeed
5	Mother (2)	1	Misrecognition
6	Mother (2)	2	Succeed
7	Adult Child (3)	3	Succeed
8	Adult Child (3)	3	Succeed
9	Adult Child (3)	3	Succeed
10	Adult Child (3)	3	Succeed

Of the 10 experiments that the author has made, there were 8 successful attempts, 1 attempt was misrecognized and 1 attempt was not detected. From these results the author can draw the conclusion that this sensor can be used for the system he created.

IoT Testing

In this test the author created a Telegram chat bot which will provide notifications if someone uses this system to carry out testing.



Figure 6. Telegram Results

From 10 attempts the results were the same as the detection and were sent to the Telegram chat. The following is an example of the results from Telegram.

After ensuring that all components are running well, in this test the author installed all the components and simulated the use of the system, carrying out 5 trials. The following are the results obtained.

Table 7. Whole System Testing

No	Fingers	Glass Color	Color Sensor	IOT
1	Father	Red	Red	Sent accordingly
2	Adult Child	Blue	Blue	Sent accordingly
3	Mother	Green	Blue	Wrong glass color
4	Father	Red	Red	Sent accordingly
5	Adult Child	Blue	Blue	Sent accordingly

From the 5 experiments above, there was one error during the 3rd experiment, namely inserting a green glass but the system detected a blue glass so the water that came out was cold water and in IoT an error also occurred. The following are the results of the tool.



Figure 7. Smart Dispenser

VI. CONCLUSION

An intelligent and efficient automatic dispenser was successfully designed and implemented by utilizing flow, proximity, color and fingerprint sensor technology, and connected to the Internet of Things (IOT) for real-time monitoring. This automatic dispenser can provide drinking water according to user preferences, depending on the color of the glass used. If the glass is red, the dispenser will fill warm water; if the glass is blue, the dispenser will fill cold water; if the glass is green, the dispenser will fill normal temperature water. This automatic dispenser can also identify users based on fingerprints and provide notifications via Telegram chat bots. This can increase the family's attention to drinking enough water every day.

From the discussion on "Implementation and Monitoring of Drinking Water Needs with IoT-Based Smart", it can be concluded that this automatic dispenser can replace conventional dispensers which have limitations and waste in the use of water and energy, as well as providing a positive impact on the environment by adding sensors to the dispenser. Making the system even more precise.

REFERENCES

- [1] R. Dimastaputra and Sutono, "Dispenser Pintar Berbasis Mikrokontroler AVR ATMEGA8535," *J. UNIKOM*, pp. 1–7, 2015.
- [2] P. R. Adinda, "RANCANG BANGUN PENUANGAN AIR MINUM OTOMATIS BERBASIS IoT MENGGUNAKAN METODE PROTOTYPING," *J. Portal Data*, vol. 2, no. 9, pp. 1–12, 2022.
- [3] F. T. Wahyuningsih, Y. Al Hakim, and A. Ashari, "Pengembangan Alat Peraga Pengukur Debit Air Menggunakan Sensor Flow Berbasis Arduino Sebagai Media Pembelajaran Fluida," *Radiasi J. Berk. Pendidik. Fis.*, vol. 12, no. 1, pp. 38–45, 2019, doi: 10.37729/radiasi.v12i1.31.
- [4] I. Zulkarnain, R. Mukhlis, and A. Badrul, "Implementasi Alat Pendeteksi Warna Benda Menggunakan Fuzzy Logic dengan Sensor TCS3200 Berbasis Arduino," *J. Teknol. Sist. Inf. dan Sist. Komput. TGD*, vol. 2, no. 2, pp. 106–117, 2019.
- [5] D. Maltoni, D. Maio, A. K. Jain, S. Prabhakar, and others, *Handbook of fingerprint recognition*, vol. 2. Springer, 2009.
- [6] H. Suhendi and H. Nasrullah, "Sentralisasi Absensi Sidik Jari Berbasis Pc Di Jaringan Lokal," *J. Online Sekol. Tinggi ...*, vol. 11, no. 1, pp. 35–44, 2015.
- [7] N. H. L. Dewi, M. F. Rohmah, and S. Zahara, "Prototype Smart Home Dengan Modul Nodemcu Esp8266 Berbasis Internet of Things (Iot)," *Teknol. Inf.*, pp. 3–3, 2019.
- [8] A. Satriadi, Wahyudi, and Y. Christiyono, "Perancangan Home Automation Berbasis NodeMcu," *Transient*, vol. 8, no. 1, pp. 2685–0206, 2019.
- [9] Salmon, H. Pratiwi, and S. A. Sadzali, "Prototipe Alat Perawatan Ikan Hias Menggunakan Nodemcu Berbasis Iot (Internet Of Things)," *J. Inform.*, vol. 13, no. 1, pp. 16–29, 2023.
- [10] D. Firmansyah, Ibrahim, and G. L. Sari, "Implementation of Automatic Pump Control on Sea Water Destillation System," *Electro Luceat*, vol. 6, no. 2, pp. 299–307, 2020, doi: 10.32531/jelekn.v6i2.268.
- [11] M. Imron and A. I. Sudrajat, "PROTOTYPEBOILER UNTUK PROSES PEMANASAN SISTEM Muhammad Imron ; 2 Ahmad Irfan Sudrajat Program Studi Teknik Elektro , Fakultas Teknik , Universitas Muhammadiyah Tangerang ABSTRAK Proses produksi merupakan jantung dari suatu industri . Industri makanan , ma," *Manaj. Syst.*, pp. 49–56, 2022.
- [12] Nofrizal and W. Agustiarmi, "Perancangan dan Pembuatan Sistem Kontrol Dispenser Otomatis Menggunakan NodeMCU ESP8266 Berbasis Internet of Things (IoT)," *Voteteknika (Vocational Tek. Elektron. dan Inform.*, vol. 12, no. 1, p. 8, 2024, doi: 10.24036/voteteknika.v12i1.125494.
- [13] N. E. Anwar and H. Ferdilla, "Pengaturan Kecepatan Dan Pengendalian Motor DC 5 V- 110 V Menggunakan IC Tipe NE 555 (Speed Regulation And Control Of 5 V-110 V DC Motor Using IC Of NE 555 Type)," vol. 1, no. 2, pp. 113–123, 2023.
- [14] R. F. Elpriza, A. R. Al Tahtawi, and S. Yahya, "Perancangan dan Implementasi Pengereman Regeneratif pada Simulator Mobil Listrik Berbasis Motor Arus Searah," *IRWNS Pros. 13th Ind. Res. Work. Natl. Semin.*, pp. 13–14, 2022.
- [15] N. Imansyah and S. H. Widiastuti, "Sistem Kontrol dan Monitoring Penggunaan Air Berbasis IoT Menggunakan Modul ESP8266," *J. Inf. dan Teknol.*, vol. 4, no. 2, pp. 108–113, 2022, doi: 10.37034/jidt.v4i3.207.

BIOGRAPHY

Rahmat Novrianda Dasmien, is the Manager of Innovation and Intellectual Property at Universitas Bina Darma. He also serves as a lecturer at the Faculty of Vocational Studies at the same university, specifically within the Computer Engineering program. His dedication to innovation and education has earned him a spot as a Top 10 Nominee for the Innovative Lecturer Award in South Sumatra.

M Yahya, chairman of the Community Information Group Coordination Forum (FK KIM) Universitas Bina Darma.